



CEILING
LIGHTING
AMBIENCE

FS4.5 KS

INSTALLATION MANUAL

GENERAL INFORMATION

GENERAL NOTES

This assembly manual addresses all metal ceilings manufactured by durlum. The different sections describe the corresponding products.

durlum is a leading German manufacturer of metal ceilings and cladding elements, mainly made of galvanised sheet steel, aluminium and expanded metal.



The relevant products are described in the marketing and sales documents. They are both acoustically effective, and can also be used as design elements only.

Specifically, these products are:

- Acoustic ceilings
- Chilled ceilings
- CHARACTER products

durlum differentiates between a wide range of ceiling systems, for example S1. "S" stands for the system, "1" for clamping. In this system, there are different nomenclatures that allow a further subdivision of the systems.

All durlum systems are systems of modular design. This applies not only to the substructure but also to the ceiling parts that are suspended, locked into place or placed on the substructure.

durlum metal ceilings comply with the standard EN 13964:2007 and are CE-certified.

For special systems marketed by us and for which no general approvals are available, there are suitable static certificates available, and suitable designs compliant with EN 13964 have been constructed.

GUIDELINES

These installation instructions have been structured in accordance with the requirement of EN 13964:2007. They describe a proper installation.

The description does not exempt the user from examining the structural conditions, implementing the building code regulations and observing the information given in the building permit prior to starting assembly. They have priority, but could not be included here.

It is advisable always to draw up assembly diagrams/drawings, to establish the location where assembly is to begin and to establish the required suspension points for the relevant ceiling system prior to starting assembly.

STRUCTURAL PRECONDITIONS

Metal ceilings may usually be installed as soon as the building is swept clean and at the latest after all wet work in the interior has been completed and the building has been closed.

Prior to starting assembly, the suspension points must be checked for their usability, and load introduction into the building must be guaranteed.

When using wall mounting points, such as brackets or wall anchors, the load-carrying capacity of the wall in question must be checked.

If ceiling elements rest on brackets, possible wall movements must be taken into account.

Only dowels for which a general building supervisory approval is available may be used, and their minimum extraction force must be greater than 100kg. The dowels must be mounted as specified by the relevant dowel manufacturer. We recommend performing regular tensile stress tests, to verify that dowels have been set correctly.

durlum metal ceilings are dimensioned such that they carry their own weight of the system construction plus a surface load amounting to 40N/m². Higher loads must be taken into account or suspended separately in the construction, and the measures must be adapted to the situation at hand. Usually, built-in components and loads must be suspended separately.

For ceiling systems that do not allow any tolerance compensation within a module, suitable material expansions must be taken into account.

Building expansion joints and tolerances customary in building construction must be taken into account accordingly.

durlum metal ceilings are, as a matter of principle, to be assembled by professional dry construction companies who are capable of assessing the overall conditions of the building, the metal ceiling and cladding, and can take the necessary precautions for correct, safe static mounting.

If parts from different manufacturers are used to assemble the ceiling, the relevant mounting company must provide the certificates required by EN 13964:2007 and must obtain suitable certificates of conformity itself.

Liability for proper selection of the products and system conformity can only be assumed for the systems delivered by durlum.

To prevent the parts from becoming dirty, gloves must be worn during assembly. If the ceiling products are delivered wrapped in a protective film, they must be protected from exposure to UV radiation [sunlight], the film must likewise have been removed from the goods no later than 4 weeks after delivery. The storage temperature must not exceed 30°C, since otherwise the adhesive on the panel may become hardened, and the protective film can no longer be removed.

STORAGE

durlum metal ceilings are usually delivered on pallets. It is advisable to leave the metal panels on the pallets as long as possible. If the pallets have to be opened, the durlum metal panel should always be positioned on the long side, it can then be placed carefully against the wall, do not store flat.

Storage must be carried out such that damage is excluded. During storage, durlum ceiling panels have to be protected from all weather influences. Panels to be stored at a constant temperature between 10°C and 40°C.

The assembly of the ceiling panels must not start until all dust-producing work has been completed [swept clean].

durlum products are certified according to ISO 9001 for development, production, sales and also for service. Nonetheless, it is recommended as a matter of principle to inspect the delivered metal ceilings immediately and to report complaints immediately [as a rule immediately after delivery or within 3 days].

GENERAL INFORMATION

STANDARDS AND REGULATIONS

The relevant regulations applicable at the installation site must be determined by the assembly company in question. The ceilings marketed by durlum comply with EN 13964. This standard also regulates the classification of fire protection.

APPLICATION

The application of durlum metal ceilings is restricted, unless agreed upon otherwise, to interiors, so that, pursuant to EN 13964, class of use 1, corrosion protection class A, has been defined here as standard.

Should it become necessary to adjust the metal ceiling panels to the building by cutting them, we recommend protecting the cutting edges from corrosion by means of paint in order to maintain the corrosion protection class A.

QUALITY STANDARD

For material properties, dimensions, tolerances, colour deviations, the TAIM Directives [Technical Association of Industrial Metal Ceiling Manufacturers] applies.

MOUNTING SEQUENCE

1. Create a ceiling layout plan or use the one from the architect.
2. Cross-check the ceiling layout plan against the on-site situation.
3. Prepare a bill of materials, including a suitable work plan and retrieval/order of the materials required.
4. Determine the required suspension points in accordance with the classes of use of EN 13964. The corresponding suspension distances for the different systems can be taken from the detailed descriptions of the individual ceiling systems.
5. Define which generally approved dowel is suitable.

Check the raw ceiling and the walls.

Mark the dowel mounting holes and drill them.

Mount the dowels as specified by the dowel manufacturer and carry out extraction tests using the device recommended by the dowel manufacturer, if necessary.

6. Follow the same procedure when

mounting the perimeter trim, mounting interval approx. 400-625 mm, check transmission of force into wall.

7. As a rule, arrangement of the panels should be from the centre of the corridor to compensate and halve the tolerances of the corridor/panels. The precise arrangement must always be done on the basis of the ceiling layout plan.
8. The metal ceiling panels are often provided with a joint tape [9x3mm], to make for easier tolerance compensation.

Should a joint tape be used, the joints must also be re-aligned from time to time, since the joint tape also has tolerances.

However, owing to the high production precision, it is also possible to connect the panels without a joint tape by using butt joints or provide them with rubber spacer naps.

Always ensure that the joints are aligned.

9. Attachments or other loads are to be mounted separately. For logical reasons these parts are integrated during the mounting process.
10. After completion and pre-acceptance of the ceiling, the sequence of joints should be re-aligned. Soiled ceiling panels should be cleaned to give a perfect result for assembly.

FS4.6 BR INSTALLATION MANUAL

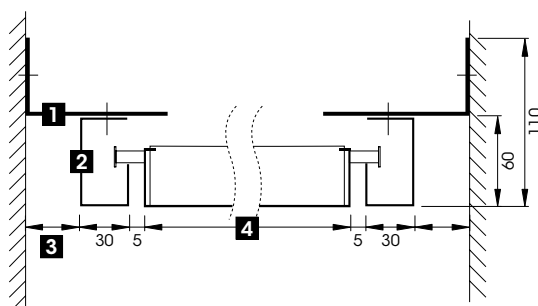
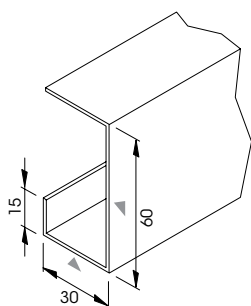
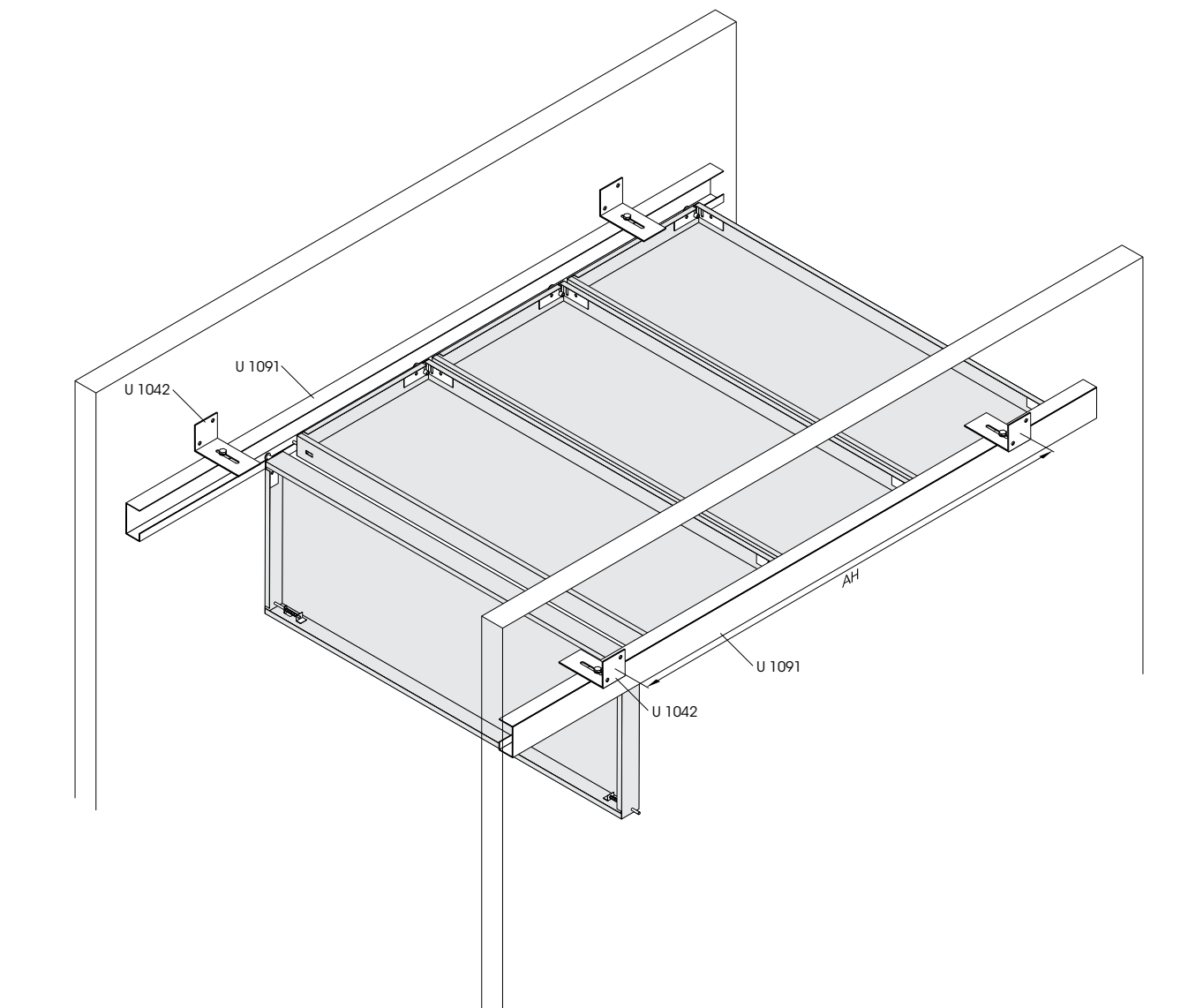

- 1** Suspension to the wall with U 1042
- 2** Perimeter hook-on profile U 1091

- 3** Joint width at option
- 4** rectangular metal panel length

FS4.6 BR INSTALLATION MANUAL

ABBREVIATIONS

AH: General distance for mounting:
Panel length up to 2500 mm = 800 mm
Panel length >2500 mm = 400 mm

This general distance is less, depending on additional loads, the type of wall and special requirements.

PLEASE NOTE

- Use only officially approved dowels.
- The fastening base must be suitable in terms of statics. It must be able to reliably absorb the forces introduced into the building.

MAXIMUM TOLERANCE COMPENSATION

- Wall connection with U 1042:
shifting range 10 - 40 mm

ASSEMBLY OF THE LONG SIDE WALL BRACKET

1. Level and outline the given ceiling height.
2. Outline the upper edge of wall anchor U 1042.
3. Mark the drill hole.
4. Drill a hole for the dowel and set dowel.
5. Screw wall anchor U 1042 together with dowel.
6. Secure the screw connection against loosening.

ASSEMBLY OF PERIMETER HOOK-ON PROFILE U 1091

1. Determine and outline the wall distance of perimeter hook-on profile U 1091.
2. Fasten perimeter hook-on profile U 1091 to wall anchor U 1042 with screw connection M6. Secure the screw connection against loosening.
3. The screwing distance must be selected analogous to the dowel fastening distance.

ASSEMBLY OF CEILING PANELS

1. Wear clean cotton gloves.
2. Remove the protective film from the ceiling panels, if available.
3. Insert the ceiling panel with the short side diagonally from below over the vertical shank of the perimeter hook-on profile.
4. Slowly lower the ceiling panel and place it with the bearing bolts and lo-

cking parts on the vertical shank of the perimeter hook-on profile.

5. Check the perpendicularity of the joint and its even width; if necessary, readjust the perimeter hook-on profiles to the required axis pitch.
 - 5.1. The standard dimensions of the short-side joint between the panel and the perimeter hook-on profile is 5 mm.
 - 5.2. The long-side joint between the panels is min. 3 mm.

DISASSEMBLY OF CEILING PANELS

1. Wear clean cotton gloves.
2. Insert a wall scraper into the long-side joint. Push both locking pins away from the perimeter hook-on profile to the centre of the panel. Lower the ceiling panel.
3. With panel lengths 1,300 mm and above, the disassembly must be performed by two persons.
4. The ceiling panel can be moved along the perimeter hook-on profiles. A maximum of three panels may be slid together.
5. Lift the ceiling panel with both bearing bolts and lower it down diagonally.
6. Put the ceiling panel down and store it protected against damage.

CEILING
LIGHTING
AMBIENCE

durlum GmbH | An der Wiese 5 | D-79650 Schopfheim

T +49 (0) 76 22 | 39 05-0
F +49 (0) 76 22 | 39 05-42
E info@durlum.com
I durlum.com