



CEILING  
LIGHTING  
**AMBIENCE**

---

# **OPEN SKY®**

## INSTALLATION MANUAL

# GENERAL INFORMATION

## GENERAL INFORMATION

This assembly manual addresses the special ceiling OPEN SKY® translucent glass ceiling manufactured by durlum.

durlum is a leading German manufacturer of metal ceilings and cladding elements, mainly made of galvanised sheet steel, aluminium and expanded metal.



The relevant products are described in the marketing and sales documents. They are both acoustically effective, and can also be used as design elements only.

Specifically, these products are:

- Acoustic ceilings
- Chilled ceilings
- CHARACTER products

All durlum systems are systems of modular design. This applies not only to the substructure but also the ceiling parts that are suspended, locked into place or placed on the substructure.

durlum ceilings conform to standard EN 13964:2007.

For special systems marketed by us and for which no general approvals are available, there are suitable static certificates available, and suitable designs compliant with EN 13964 have been constructed. If necessary, individual approvals are required.

durlum lighting complies with the standard EN 60598:1 and is CE-certified.

## GUIDELINES

These installation instructions have been

structured in accordance with the requirement of EN 13964:2007 and describe a proper assembly.

The description does not exempt the user from examining the structural conditions, implementing the building code regulations and observing the information given in the building permit prior to starting assembly. They have priority, but could not be included here.

It is advisable always to draw up assembly diagrams/drawings, to establish the location where assembly is to begin and to establish the required suspension points for the relevant ceiling system prior to starting assembly.

## STRUCTURAL PRECONDITIONS

Ceilings may usually be installed as soon as the building is swept clean, but at least when all wet work in the interior has been completed and the building has been closed.

Prior to starting assembly, the suspension points must be checked for their usability, and load introduction into the building must be guaranteed.

When using wall mounting points, such as brackets or wall anchors, the load-carrying capacity of the wall in question must be checked.

If ceiling elements rest on brackets, possible wall movements must be taken into account.

Only anchors for which a general building supervisory approval is available may be used, and their minimum extraction force must be greater than 100kg. The anchors must be mounted as specified by the relevant anchor manufacturer. We recommend performing regular tensile stress tests, to verify that anchors have been set correctly.

durlum ceilings are dimensioned such that they carry their own weight of the system construction. Higher loads must be taken into account or suspended separately in the construction, and the measures must be adapted to the situation at hand. Usually, built-in components and loads must be suspended separately.

For ceiling systems that do not allow any tolerance compensation within a module, suitable material expansions must be taken into account.

Building expansion joints and tolerances customary in building construction must be taken into account accordingly.

durlum ceilings must always be assembled by expert dry building companies who are capable of assessing the overall situation in the building, the metal ceiling, and cladding surface and taking suitable precautions for ensuring proper assembly that is safe in terms of statics.

If parts from different manufacturers are used to assemble the ceiling, the relevant mounting company must provide the certificates required by EN 13964:2007 and must obtain suitable certificates of conformity itself.

Liability for proper selection of the products and system conformity can only be assumed for the systems delivered by durlum.

To prevent the parts from becoming dirty, gloves must be worn during assembly. If the ceiling and lighting products are delivered laminated with a protective film, they must be protected from exposure to UV radiation [sunlight], the film must likewise have been removed from the goods no later than 4 weeks after delivery. The storage temperature must not exceed 30°C, since otherwise the adhesive on the panel may become hardened, and the protective film can no longer be removed.

## STORAGE

durlum ceilings are usually delivered on pallets. It is advisable to leave the glass panels on the pallets as long as possible. If the pallets need to be opened, the durlum glass panel should always be placed on its longitudinal side.

Storage must be carried out such that damage is excluded.

The assembly of the glass panels must not start until all dust-producing work has been completed [swept clean].

The glass elements are to be transported with special lifters [suction devices].

durlum products are certified according to ISO 9001 for development, production, sales and also for service. Nevertheless, it is recommended subjecting the supplied ceilings always immediately to an inspection and reporting any complaints right away [usually immediately following delivery or within 3 days].

## STANDARDS AND REGULATIONS

The relevant regulations applicable at the installation site must be determined by the assembly company in question. The ceilings marketed by durlum conform to EN 13964. This standard also regulates the

classification of fire protection. The durlum luminaires comply with EN 60598-1.

## APPLICATION

The application of durlum ceilings is restricted, unless agreed upon otherwise, to interiors, so that, pursuant to EN 13964, class of use 1, corrosion protection class A, has been defined here as standard.

The use of durlum lighting is restricted to interiors. The lighting complies with protection class IP 20, protection class 1 according to EN 60598-1.

## MOUNTING SEQUENCE

1. Prepare ceiling-luminaire installation plan or adopt architect's plan.
2. Check the ceiling-luminaire installation plan against structural conditions. The position of the sub-construction to the lighting is to be checked as well as the hinge direction of the glass.
3. Prepare a bill of materials, including a suitable work plan and retrieval/order of the materials required.
4. Determine the required suspension points in accordance with the classes of use of EN 13964. The corresponding suspension distances for the different systems can be taken from the detailed descriptions of the individual ceiling systems.
5. Establish which generally approved anchor is suitable. Check the raw ceiling and the walls. Mark the anchor mounting holes and drill them. Mount the anchors as specified by the anchor manufacturer and carry out extraction tests using the device recommended by the anchor manufacturer, if necessary.
6. Use the same procedure when mounting the wall brackets, mounting distance about 400–625mm, check the introduction of force into the wall.
7. Shorten intended fastening elements, such as the M12 threaded rod to the intended length or order the correct length and mount it on the raw ceiling.
8. Usually, the panel layout should be started from the centre of the room, in order to be able to compensate the tolerance of the room and cut the panels in half, if necessary. The precise arrangement must always be done on the basis of the ceiling lighting layout plan.
9. Use the layout plan to determine in

which direction the cross reinforcement profiles are laid, either in parallel to the façade [usually] or vertically to the façade. The respective primary profiles are mounted at a right angle to the secondary profiles. To this end, the system-specific connecting elements are used, see system descriptions. The position of the primary profiles is established in the reflected ceiling plan.

10. After completion and pre-acceptance of the ceiling, the sequence of joints should be re-aligned. Dirty ceiling panels should be cleaned, to obtain a perfect appearance of the finished ceiling.

# OPEN SKY® INSTALLATION MANUAL

- 010 Anchors M10
- 020 Hanging loop
- 030 Threaded rod M12
- 040 Nut M12
- 050 Washer M12
- 060 Wide span carrier as primary profile
- 070 Wide span carrier as secondary profile
- 080 Connector
- 090 Strape
- 100 Connecting stud M10
- 110 Suspensionbox Type A
- 120 Screw M8×40 [DIN 912]
- 130 Washer M8 [DIN 125]
- 140 Wing nut M8
- 150 Rubber washer 1 mm black
- 160 Safety cable with damper
- 170 Special screw incl. protective sleeve
- 180 DUROPLAN® glass insert TVG 2×5 mm

- 190 Tool for 2-hole special screw

## Remarks:

1. Circumferential joint  $\geq 8$ mm.
2. To prevent movement and vibration, we recommend using threaded rods  $\geq$  M10 next to each suspensionbox.

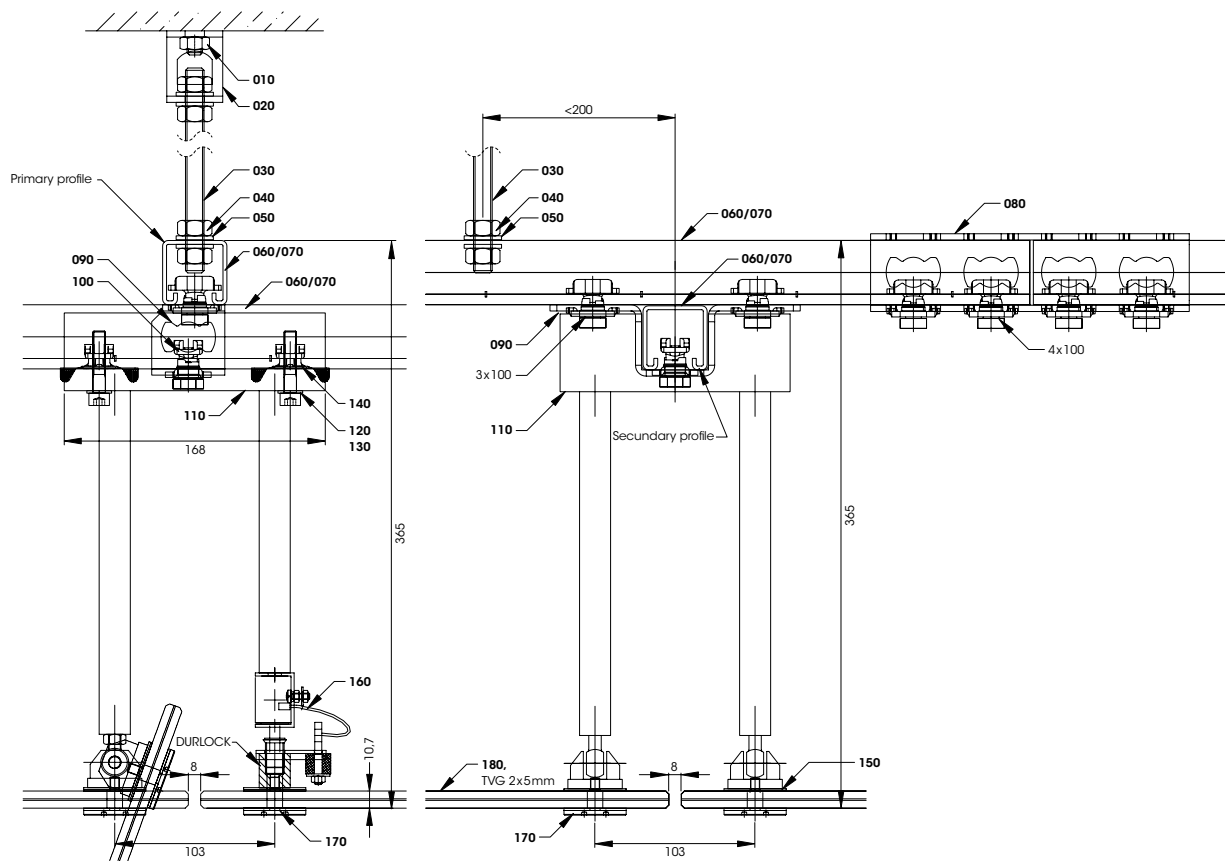

## Suspensionbox Type A [2x joints and 2x DURLOCK]

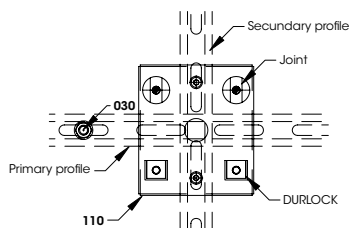

## Ceiling layout

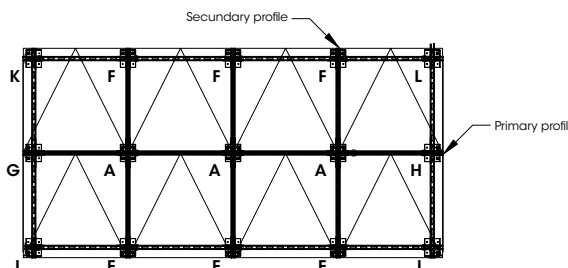

## DISTANCES ETC.

### AS: Distance of primary and secondary profiles

- depends on module
- Minimum module: 500mm x 500mm
- Maximum module: 1 200 x 1 200mm

### Number of suspensions points

The number of suspension points corresponds to the number of suspension boxes.

## PLEASE NOTE

- Use only officially approved anchors.
- The fastening base must be suitable in terms of statics. It must be able to absorb the forces introduced into the building.
- Measurement of the suspension points and setting of the anchors.
- If necessary, the contractor may be requested to provide static calculations for the constructions.
- The ceiling plan is to be prepared by the contractor.

## ASSEMBLY SEQUENCE

1. Set anchor [010] in raw ceiling, in the region of each box [110]. Max. distance 200mm from centre of box.
2. Assemble OPEN SKY® suspension bracket [020] with nut M12 [040].
3. Assemble M12 threaded rod [030] and mount the wide span carrier profile at horizontal level [primary carrier] [060 or 070] with nuts M12 [040] and washers M12 [050]. If necessary, the wide span carrier is to be adapted in length on the building side. Attention: the wide span carriers must be dimensioned precisely in accordance with the box position points as they determine the position of the box.
4. The mounting level is established via a laser or hose level.
5. The connector [080] is pushed onto the face of the wide span carrier. Please note: the connectors are to be mounted offset [not on the same cross axis].
6. The wide span profile [secondary carrier] [060 or 070] is screwed to the primary carrier via the OPEN SKY® bride [090] and connecting stud [100] [1x per box].
7. Mounting of the box [110] to the secondary carrier is via 2 wing nuts M8 [140], screws M8 [120] and washers M8 [130]. There are 12 standard types of boxes. Type A is depicted in the illustration as an example.
8. Pre-assemble the reflector on the lighting unit. In each case, secure to front side with 2 DIN 7985 M4x6 and serrate washers DIN 6798 with cross slit H [detail according to M-OS0871-SY\_de]. Re-

move the foil.

9. Loosen 4 screws with cross slit H on lighting unit [detail B1] according to the wide span carrier profile. Place wing nut on primary profile and twist [B3B].
10. Place lighting unit on the primary profile and arrange central to the module, arrange asymmetrical reflectors at the border according to ceiling plan [Fig. A2].
11. Re-tighten screws [see point 9].
12. Push wing nut into longitudinal hole of connector to primary profile and screw tight with M8 screw [key size 13].
13. Electrical connection via Wieland GST15i3 or GST15i5 to power supply on building side with socket and lighting units to each other. The electrical circuits are to be defined in advance by the electrical company [i.e. how many elements can be switched in sequence].
14. Pull the cable tight at the clips to avoid creating shadows.
15. Insert lighting units and burn in.
16. Fit a rubber washer [150] at every suspension arm.
17. Die DUROPLAN® glass panel [180] is first mounted in a vertical position to the joint [170] [do not lose protective sleeve].
18. The DUROPLAN® glass panel is secured on the DURLOCK side with the safety cable [160].
19. The special stainless steel screws [170] are tightened with tool [190].

## HINGE THE GLASS PANELS

1. Have qualified personnel separate the system from the power supply.
2. The joints of the glass panels must always be absolutely parallel to allow hinging of the elements.
3. Apply even pressure on the glass panel using both hands. Wear gloves.
4. After release from the DURLOCK, release the snap hook from the safety while holding the glass panel firmly. The glass panel can now be hinged slowly downwards.
5. Lighting units are to be replaced by qualified personnel.
6. Cleaning: reflectors are to be cleaned dry at regular intervals by qualified personnel [at normal soiling], clean glass panel professionally in hinged down position.

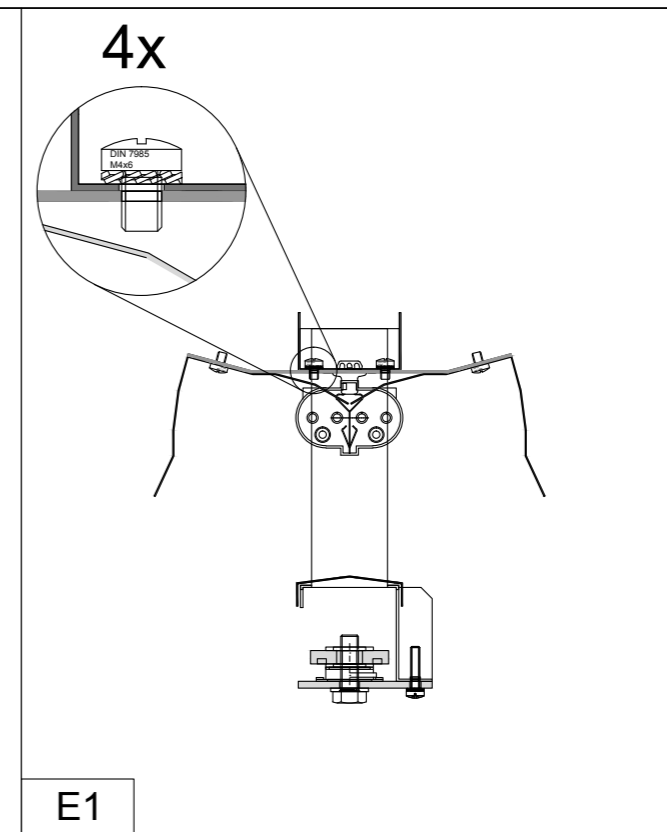
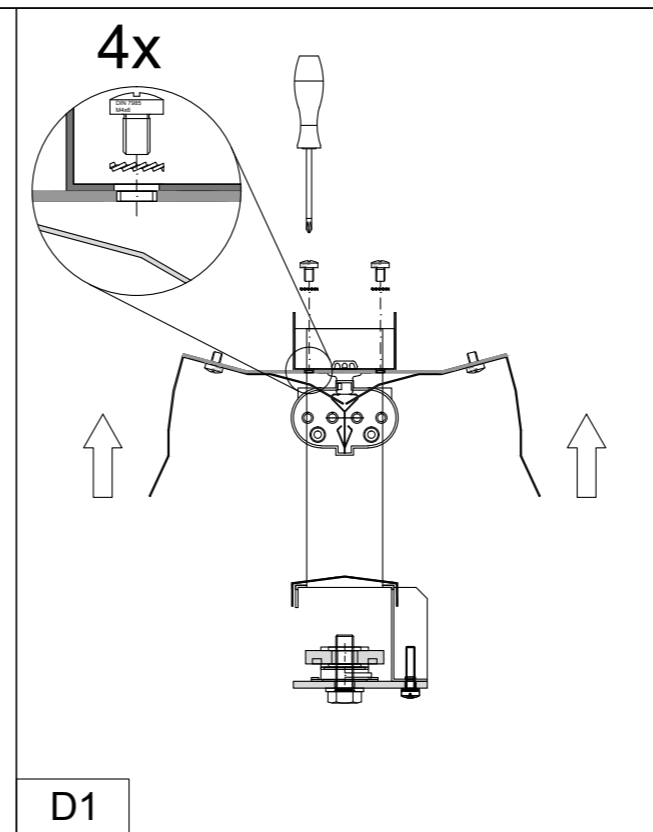
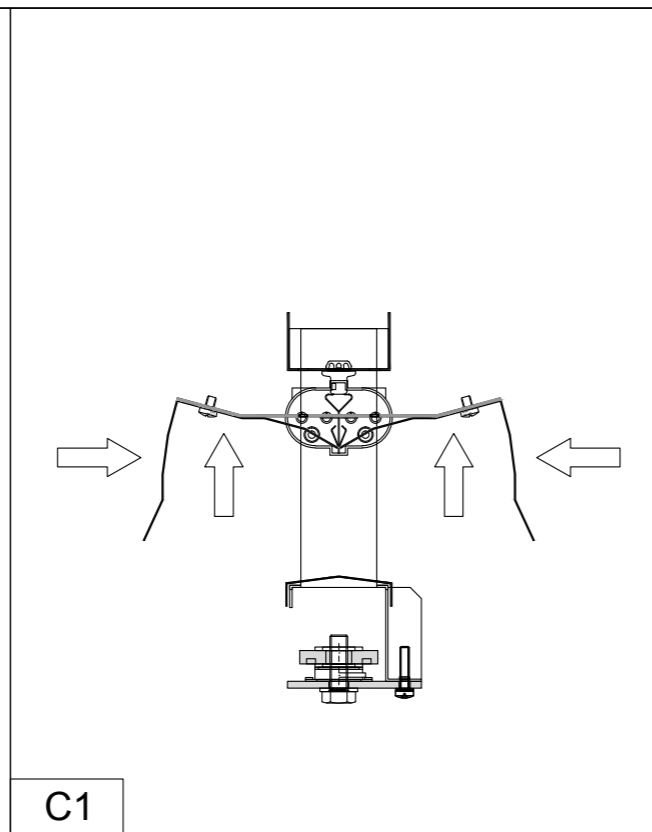
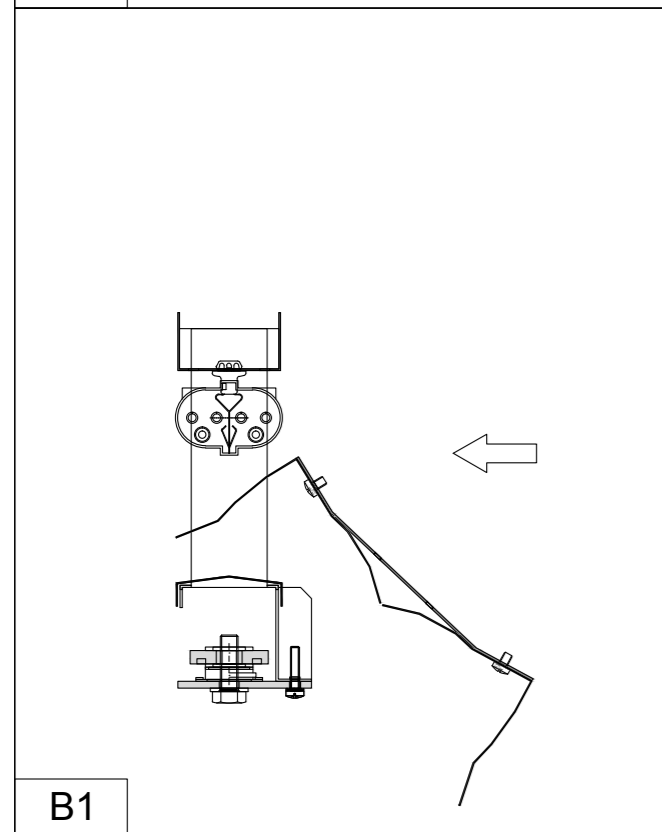
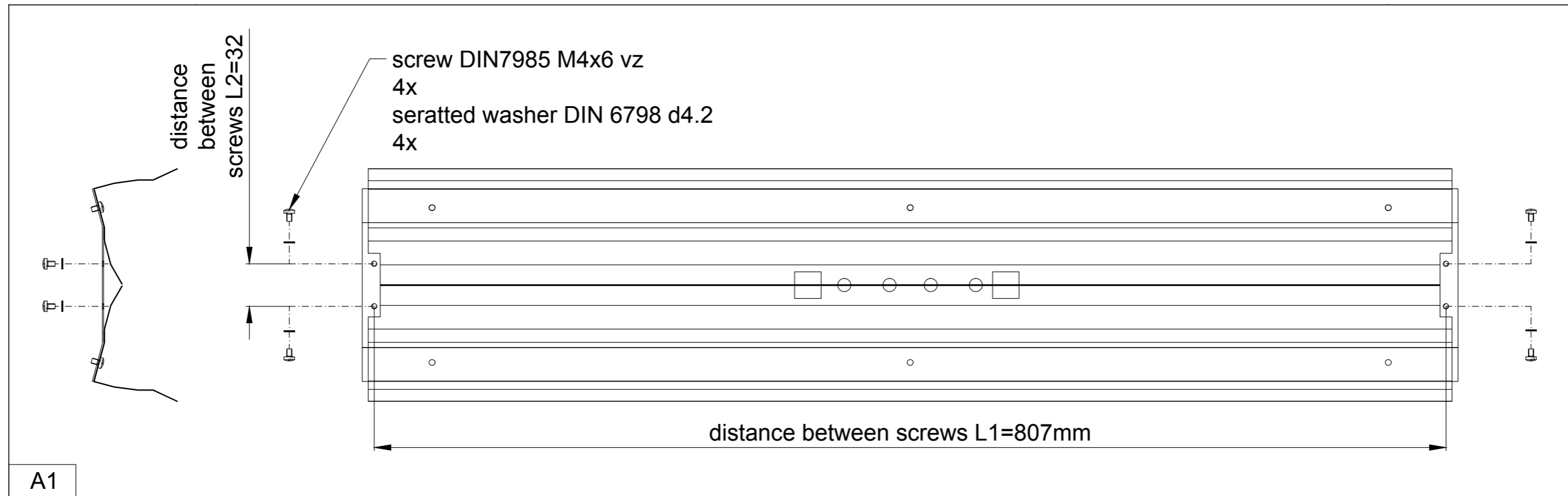

This drawing is passed on with all rights reserved to **durlum**, and must ONLY be used for common purpose projects.  
Transmission to third parties especially to competitors is prohibited! **durlum** GmbH, Schopfheim, Germany  
All technical modifications to be reserved.

DIN A3	mounting instruction	drawn.: 11.07.2013	Rev.: 15.08.2013	M-OS0871-SY_en	P01/01
--------	----------------------	--------------------	------------------	----------------	--------

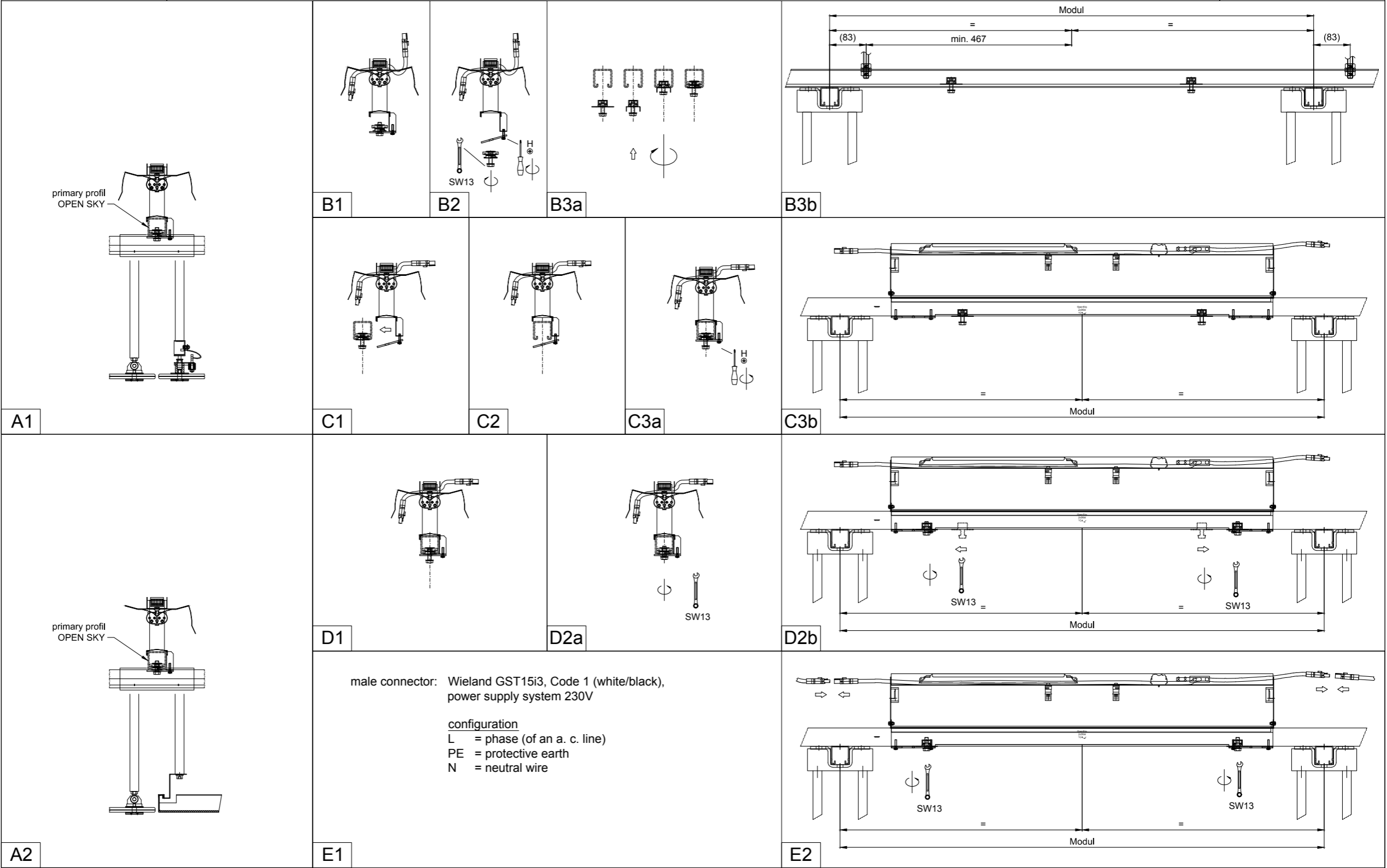

This drawing is passed on with all rights reserved to **durlum**, and must ONLY be used for common purpose projects. Transmission to third parties especially to competitors is prohibited! **durlum** GmbH, Schopfheim, Germany. All technical modifications to be reserved.

male connector: Wieland GST15i5, Code 2 (lightblue),  
power supply system 230V and 1-10V dim.

configuration

D1 = plus pole (+) (black)  
D2 = minus pole (-) (grey)  
L = phase (of an a. c. line) (braun)  
PE = protective earth  
N = neutral wire

E1

M-OS0871-236-11\_en | P01/01

male connector: Wieland GST15i5, Code 2 (lightblue),  
power supply system 230V and DALI dim.

configuration

D1 = DALI +  
D2 = DALI -  
L = phase (of an a. c. line) (braun)  
PE = protective earth  
N = neutral wire

E1

M-OS0871-236-21\_en | P01/01





CEILING  
LIGHTING  
**AMBIENCE**

---

**durlum GmbH** | An der Wiese 5 | D-79650 Schopfheim

T +49 (0) 76 22 | 39 05-0  
F +49 (0) 76 22 | 39 05-42  
E [info@durlum.com](mailto:info@durlum.com)  
I [durlum.com](http://durlum.com)