



CEILING
LIGHTING
AMBIENCE

POLYLAM®

INSTALLATION MANUAL

GENERAL INFORMATION

This assembly manual addresses all metal ceilings manufactured by durlum. The different sections describe the related/relevant products.

durlum is a leading German manufacturer of metal ceilings and cladding elements, mainly made of galvanised sheet steel, aluminium and expanded metal.



The relevant products are described in the marketing and sales documents. They are both acoustically effective, and can also be used as design elements only. Specifically, these products are:

- Acoustic ceilings
- Chilled ceilings
- CHARACTER products

durlum differentiates between a wide range of ceiling systems, for example S1. "S1" stands for system 1 clamping. In this system, there are different nomenclatures that allow a further subdivision of the systems.

All durlum systems are systems of modular design. This applies not only to the substructure but also the ceiling parts that are suspended, locked into place or placed on the substructure.

durlum metal ceilings comply with the standard EN 13964:2007 and are CE-certified. Appropriate static certificates are available for special systems marketed by us and for which no general approvals are available, and appropriate designs compliant with EN 13964 have been constructed. durlum lamps comply with standard EN 60598-1 and are CE-certified.

GUIDELINES

These installation instructions have been structured in accordance with the requirement of EN 13964:2007 and describe a proper assembly.

The description does not exempt the user from examining the structural conditions, implementing the building code regulations and observing the information given in the building permit prior to starting assembly. They have priority, but could not be included here.

It is advisable always to draw up assembly diagrams/drawings, to establish the location where assembly is to begin and to establish the required suspension points for the relevant ceiling system prior to starting assembly.

STRUCTURAL PRECONDITIONS

Metal ceilings may usually be installed as soon as the building is swept clean, but at least when all wet work in the interior has been completed and the building has been closed.

Prior to starting assembly, the suspension points must be checked for their usability, and load introduction into the building must be guaranteed.

When using wall mounting points, such as brackets or wall anchors, the load-carrying capacity of the wall in question must be checked.

If ceiling elements rest on brackets, possible wall movements must be taken into account.

Only anchors for which a general building supervisory approval is available may be used, and their minimum extraction force must be greater than 100kg. The anchors must be mounted as specified by the relevant anchors manufacturer. We recommend performing regular tensile stress tests, to verify that anchors have been set correctly.

durlum metal ceilings are dimensioned such that they carry their own weight of the system construction plus a surface load amounting to 40N/m². Higher loads must be taken into account or suspended separately in the construction, and the measures must be adapted to the situation at hand. Usually, built-in components and loads must be suspended separately.

For ceiling systems that do not allow any tolerance compensation within a module, suitable material expansions must be taken into account.

Building expansion joints and tolerances customary in building construction must be taken into account accordingly.

durlum metal ceilings must always be assembled by expert dry building companies who are capable of assessing the overall situation in the building, the metal ceiling, the cladding surface, as well as the structural conditions and are able to take suitable precautions for ensuring proper assembly.

If parts from different manufacturers are used to assemble the ceiling, the relevant mounting company must provide the certificates required by EN 13964:2007 and must obtain suitable certificates of conformity itself.

Liability for proper selection of the products and system conformity can only be assumed for the systems delivered by durlum.

To prevent the parts from becoming dirty, gloves must be worn during assembly. If the ceiling products are delivered laminated with a protective film, they must be protected from exposure to UV radiation [sunlight], the film must likewise be removed from the goods no later than 4 weeks after delivery, and the storage temperature must not exceed 30°, since otherwise the adhesive on the panel may become hardened, and the protective film can no longer be removed.

STORAGE

durlum metal ceilings are usually delivered on pallets. It is advisable to leave the metal panels on the pallets as long as possible. If the pallets need to be opened, the durlum POLYLAM® should always be placed on its underside.

Storage must be carried out such that damage is excluded.

The assembly of the ceiling panels must not start until all dust-producing work has been completed [swept clean].

durlum products are certified according to ISO 9001 for development, production, sales and also for service. Nevertheless, it is recommended to always subject the metal ceilings immediately to an inspection and to report any complaints right away [usually immediately following delivery or within 3 days]. Visible damage must be noted on the delivery note.

STANDARDS AND REGULATIONS

The relevant regulations applicable at the installation site must be determined by

the assembly company in question. The ceilings marketed by durlum conform to EN 13964. This standard also governs fire behaviour in accordance with EN 13501. The durlum lighting technology complies with EN 60598-1.

APPLICATION

The application of durlum metal ceilings is restricted, unless agreed upon otherwise, to interiors, so that, pursuant to EN 13964, class of use A [table 8], corrosion protection class A [table 9], has been defined here as standard. The use of durlum lighting is restricted to interiors. The lighting complies with protection class IP 20, protection class 1 according to EN 60598-1.

Should it become necessary to adjust the metal ceiling panels to the building by cutting, we recommend protecting the cutting edges from corrosion by means of a paint or using an oil.

Assembly must be performed by skilled personnel who are familiar with all tools and machines required for assembly, such as drilling, types of anchors, laser adjustment, flexible tube level and spirit level, length measuring systems, circular saws and jigsaws.

QUALITY STANDARD

For material properties, dimensions, tolerances, colour deviations, the TAIM Directives [Technical Association of Industrial Metal Ceiling Manufacturers] applies. The TAIM Directives can be found in the Appendix of this assembly manual or at www.taim.info.

MOUNTING SEQUENCE

1. Prepare ceiling- and lighting installation plan or adopt architect's plan.
2. Check ceiling lighting installation plan versus structural conditions.
3. Prepare a bill of materials, including a suitable work plan and retrieval/order of the materials required.
4. Determine the required suspension points in accordance with the classes of use of EN 13964 [table 6]. The corresponding suspension distances for the different systems can be taken from the detailed descriptions of the individual ceiling systems.
5. Establish which generally approved anchor is suitable. Check the raw ceiling and the walls. Mark the anchor mounting holes and drill them. Mount

the anchors as specified by the anchor manufacturer and carry out extraction tests using the device recommended by the anchor manufacturer, if necessary.

6. Use the same procedure when mounting the wall brackets, mounting distance about 400–625mm, check the introduction of force into the wall.
7. Shorten intended fastening elements, such as the M6/M8 threaded rod to the intended length or order the correct length and mount it on the raw ceiling.
8. Usually, the panel layout should be started from the centre of the room, in order to be able to compensate the tolerance of the room and cut the panels in half, if necessary. The precise arrangement must always be done on the basis of the ceiling layout plan.
9. durlum metal ceilings are usually provided with a cross support [primary profile]. This is to be aligned exactly flush with the specified height. [horizontally or according to the ceiling plan].
10. Use the layout plan to determine in which direction the cross reinforcement profiles are laid, either in parallel to the façade [usually] or vertically to the façade. The cross reinforcement profiles should be mounted via a wall anchor or via a diagonal anchoring to prevent an axial movement. The corresponding secondary profiles are mounted at right angles to the primary profiles. To this end, the system-specific connecting elements are used, see system descriptions. The position of the secondary profiles is established in the reflected ceiling plan and must be adjusted to the panel dimensions.
11. After completion and pre-acceptance of the ceiling, the sequence of joints should be re-aligned and dirty ceiling panels should be cleaned, to obtain a perfect appearance of the finished ceiling.

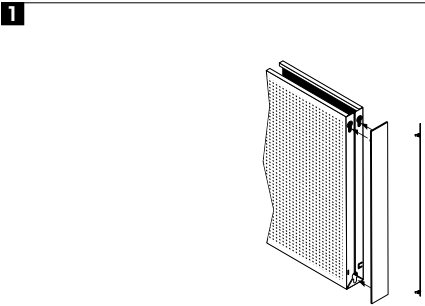
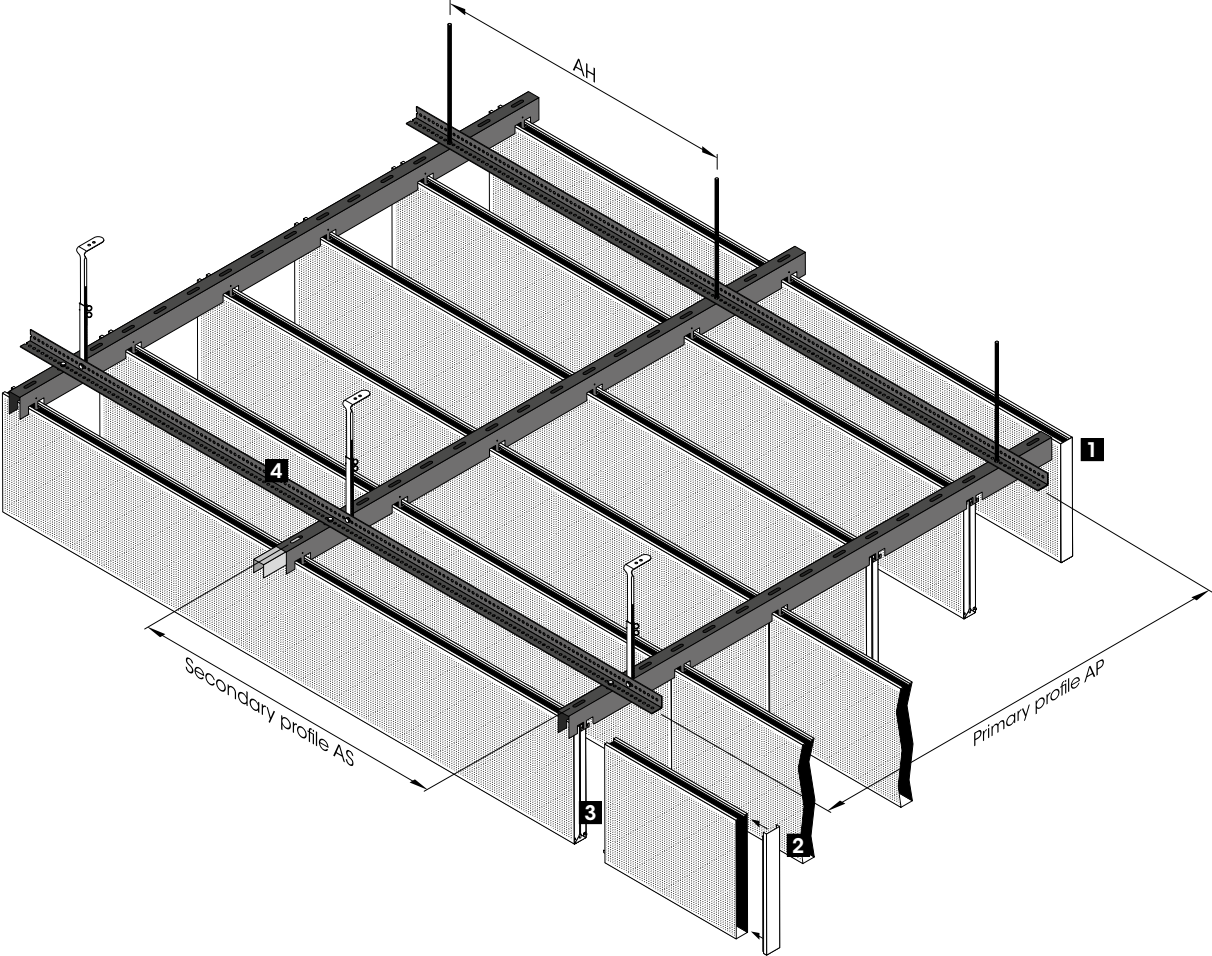

End cover

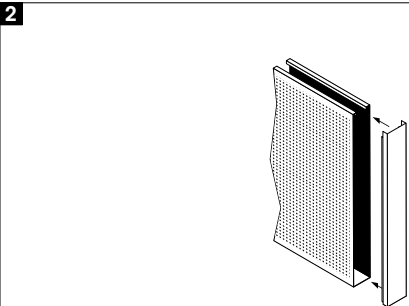

End cover with 'F' lip

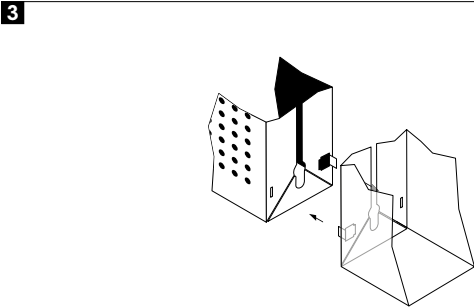

Connection detail

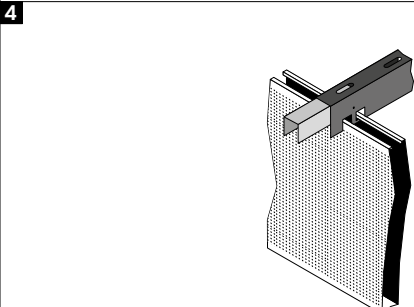

Carrier with hook punchings

ABBREVIATIONS

AH: Distance of the suspensions in axial direction of the primary profile
 AP: Distance of the primary profiles
 AS: Distance of the secondary profiles

DISTANCE OF THE SUSPENSIONS, ETC.

Distance of the AP primary profiles according to EN 13964:

Recommended every 1500mm [facilitates flush alignment and parallel mounting] or as directly mounted suspension.

Distance of the AS secondary profiles according to EN 13964:

- Depending on the length of the baffles [at the ends of the baffles] and at least every 1500mm for a baffle weight of 15kg/serial metre of carrier.
- Depending on the length of the baffles [at the ends of the baffles] and at least every 500mm for a baffle weight of max. 30kg/serial metre of carrier. It is essential that the secondary profile be mounted parallel and with flush alignment.

Distance of the AH suspensions points:

Class 2: direct mounting to secondary profile or max. ±150mm next to secondary profile support interval max. 500mm at 30kg/serial metre per secondary profile and 1000mm at 15kg/serial metre per secondary profile.

Load-carrying capacity of the suspension points [tensile loads]:

- Maximum load per Nonius suspension: 200N
- Maximum load per M6 threaded rod: 500N

Deflection classes according to EN 13964, Table 6:

Maximum additional load: 40N/m²

Classes of use if not agreed upon otherwise according to EN 13964 Table 7:

Class of use A

PLEASE NOTE

- Use only officially approved anchors.
- The fastening base must be suitable in terms of statics. It must be able to reliably absorb the forces introduced into the building [anchor loads].
- Measurement of the suspension points [AH] and setting of the anchors. The interval depends on the prevailing load.
- Mounting the AP primary profiles Interval according to classes of use.
- Mounting of the secondary profiles [AS] according to the length of the baffles, at the baffle ends, but approx. every 1500mm.

ASSEMBLY SEQUENCE

1. Set anchors.
2. Mount the Nonius upper parts or the threaded rods on the raw ceiling.
3. Nonius suspension:
 - 3.1. The lower Nonius part U 1370 is screwed together with the primary profile U 1040 and secured against loosening.
 - 3.2. The mounting level of the primary profile U 1040 is established via a laser or hose level.
 - 3.3. The upper Nonius part is screwed to the raw ceiling with approved anchors and bent. The length is determined in accordance with the suspension height.
 - 3.4. The Nonius upper part and the Nonius lower part are slid into each other, the height is adjusted and the two parts are connected using two safety pins U 1372.
 - 3.5. The adjusted lower Nonius part is now screwed to the profile U 1040 with an M6 screw.
4. Threaded rod suspension:
 - 4.1. Set approved anchors for M6 threaded rod.
 - 4.2. Order threaded rod according to the suspension height and suspend it.
 - 4.3. The threaded rod is screwed to the primary profile U 1040 and secured against being loosened.
 - 4.4. The mounting level of the primary profile is established via a laser or hose level.
5. The longitudinal joint U 1041 is slid into the joint of the primary profiles and then screwed in place.
6. Wall connection takes place via U 1042, which is screwed to the wall and to the profile.
7. The 75-POLY-UTS is connected to the U 1040 via M6-screws/nuts and secured against loosening. The parallel running carriers must be aligned exactly with the hook punchings for the baffles. Only then is alignment of the POLYLAM® baffles guaranteed.
8. The centring cone on the front face of the POLYLAM® baffle is twisted out with a screwdriver.
9. The POLYLAM® baffles are hooked on to the 75-POLY-UTS in an interlocking manner and connected at the longitudinal joint via the centring cone.
10. In as far as intended, the anti-lifting lock is placed on the baffle and secured with a self tapping screw, at least 2 per baffle.
11. For wall connection, the elements can be adapted to the room by cutting them with a suitable saw. The cut edge is covered with an end cover with F-lip. The end cover is secured with adhesive or screws. Alternatively, special elements with open wall connection and

top view of the front face can be supplied with press-on covers.

Special features for mounting POLYLAM® elements with integrated lighting:

1. The lighting is fitted ex-works to the POLYLAM® elements. There is 1 supply line for each element [without through-wiring].
2. The POLYLAM® element with lighting is hooked on as described in point 9 and secured with 2 anti-lifting locks per element [as in point 10]. Elements with a Wieland GST plug can be connected to a socket installed by an electrician. Installation of lighting without these plugs may only be performed by authorized electricians. Mount ballast units/driver in ceiling cavity, possibly on U 1040 or in the POLYLAM® baffle.
3. Perform electrical connection of the driver. Attention: to be done by authorized electrician only.
4. Connect the ballast units/drivers via plugs. If a system has no plugs, wiring may only be performed by an authorized electrician.
5. Prior to acceptance, align the elements precisely, in as far as they have been moved by other installers.

DISMOUNTING SEQUENCE

In as far as present, remove anti-lifting lock, loosen 2 POLYLAM® baffles from the connection joint [centring cone] and remove via hooks.

DECKE LICHT RAUM

CEILING LIGHTING AMBIENCE
PLAFOND LUMIERE AMBIANCE

durlum GmbH | An der Wiese 5 | D-79650 Schopfheim

T +49 (0) 76 22 | 39 05-0

F +49 (0) 76 22 | 39 05-42

E info@durlum.com

I www.durlum.com