



CEILING
LIGHTING
AMBIENCE

OPEN-CELL CEILINGS

INSTALLATION MANUAL

GENERAL INFORMATION

GENERAL INFORMATION

This assembly manual addresses all metal ceilings manufactured by durlum. The different sections describe the corresponding products.

durlum is a leading German manufacturer of metal ceilings and cladding elements, mainly made of aluminium.



All durlum systems are systems of modular design. This applies not only to the substructure but also to the ceiling parts that are suspended, locked into place or placed on the substructure.

durlum metal ceilings comply with the standard EN 13964:2007 and are CE-certified.

GUIDELINES

These installation instructions have been structured in accordance with the requirement of EN 13964:2007. They describe a proper installation.

The description does not exempt the user from examining the structural conditions, implementing the building code regulations and observing the information given in the building permit prior to starting assembly. They have priority, but could not be included here.

It is advisable always to draw up assembly diagrams/drawings, to establish the location where assembly is to begin and to establish the required suspension points for the relevant ceiling system prior to starting assembly.

STRUCTURAL PRECONDITIONS

Metal ceilings may usually be installed as soon as the building is swept clean and at the latest after all wet work in the interior has been completed and the building has been closed.

Prior to starting assembly, the suspension points must be checked for their usability, and load introduction into the building must be guaranteed.

When using wall mounting points, such as brackets or wall anchors, the load-carrying capacity of the wall in question must be checked.

If ceiling elements rest on brackets, possible wall movements must be taken into account.

Only dowels for which a general building supervisory approval is available may be used, and their minimum extraction force must be greater than 100 kg. The dowels must be mounted as specified by the relevant dowel manufacturer. We recommend performing regular tensile stress tests, to verify that dowels have been set correctly.

durlum metal ceilings are dimensioned such that they carry their own weight of the system construction plus a surface load amounting to 40 N/m². Higher loads must be taken into account or suspended separately in the construction, and the measures must be adapted to the situation at hand. Usually, built-in components and loads must be suspended separately.

For ceiling systems that do not allow any tolerance compensation within a module, suitable material expansions must be taken into account.

Building expansion joints and tolerances customary in building construction must be taken into account accordingly.

durlum metal ceilings are, as a matter of principle, to be assembled by professional dry construction companies who are capable of assessing the overall conditions of the building, the metal ceiling and cladding, and can take the necessary precautions for correct, safe static mounting.

If parts from different manufacturers are used to assemble the ceiling, the relevant mounting company must provide the certificates required by EN 13964:2007 and must obtain suitable certificates of conformity itself.

Liability for proper selection of the products and system conformity can only be assumed for the systems delivered by durlum.

To prevent the parts from becoming dirty, gloves must be worn during assembly. If the ceiling products are delivered wrapped in a protective film, they must be protected from exposure to UV radiation [sunlight], the film must likewise have been removed from the goods no later than 4 weeks after delivery. The storage temperature must not exceed 30° C, since otherwise the adhesive on the panel may become hardened, and the protective film can no longer be removed.

STORAGE

durlum metal ceilings are usually delivered on pallets. It is advisable to leave the metal panels on the pallets as long as possible. If the pallets have to be opened, the durlum metal panel should always be positioned on the long side, it can then be placed carefully against the wall, do not store flat.

Storage must be carried out such that damage is excluded. During storage, durlum ceiling panels have to be protected from all weather influences. They have to be stored at a constant temperature of between at least 10°C and at most 40°C.

The assembly of the ceiling panels must not start until all dust-producing work has been completed [swept clean]. durlum products are certified according to ISO 9001 for development, production, sales and also for service. Nonetheless, it is recommended as a matter of principle to inspect the delivered metal ceilings immediately and to report complaints immediately [as a rule immediately after delivery or within 3 days].

STANDARDS AND REGULATIONS

The relevant regulations applicable at the installation site must be determined by the assembly company in question. The ceilings marketed by durlum comply with EN 13964. This standard also regulates the classification of fire protection.

APPLICATION

The application of durlum metal ceilings is restricted, unless agreed upon otherwise, to interiors, so that, pursuant to EN 13964, class of use 1, corrosion protection class A, has been defined here as standard.

QUALITY STANDARD

For material properties, dimensions, tolerances, colour deviations, the TAIM Directives [Technischer Arbeitskreis Industrieller Metaldeckenhersteller e.V.] (Technical Association of Industrial Metal Ceiling Manufacturers) applies.

OPEN-CELL CEILINGS INSTALLATION MANUAL

MOUNTING SEQUENCE

1. Create a ceiling layout plan or use the one from the architect.
2. Cross-check the ceiling layout plan against the on-site situation.
3. Prepare a bill of materials, including a suitable work plan and retrieval/order of the materials required.
4. Determine the required suspension points in accordance with the classes of use of EN 13964. The corresponding suspension distances for the different systems can be taken from the detailed descriptions of the individual ceiling systems.
5. Define which generally approved dowel is suitable. Check the raw ceiling and the walls.

Mark the dowel mounting holes and drill them.

Mount the dowels as specified by the dowel manufacturer and carry out extraction tests using the device recommended by the dowel manufacturer, if necessary.

6. Follow the same procedure when mounting the perimeter trim, mounting interval approx. 400-625 mm, check transmission of force into wall.
7. Shorten the provided fastening elements, such as the M6/M8 threaded rod to the intended length or order the correct length and mount it on the raw ceiling.
8. As a rule, arrangement of the panels should be from the centre of the room to compensate or halve the tolerances of the room/panels. The precise arrangement must always be done on the basis of the ceiling layout plan.
9. As a rule, durlum metal ceilings are provided with cross grids [primary profile].
10. Use the layout plan to determine in which direction the cross-bracing profiles are laid, either in parallel to the façade [usually] or vertically to the façade. The cross bracing profiles should be mounted via a wall bracket or via a diagonal anchoring to prevent shifting in transverse direction.



The respective primary profiles are mounted at a right angle to the secondary profiles. To this end, the system-specific connecting elements are used, see system descriptions.

The position of the primary profiles is defined in the reflected ceiling plan.

11. If the panels are placed on a perimeter trim, we recommend our F-bracket as bracket or as stepped F-bracket. The bracket secures the panel and protects it against lifting. The ceiling panel is cut with electric sheet shears [i.e. Treco shears] and adapted to the prevailing room dimensions.
12. Attachments or other loads are to be mounted separately. For logical reasons these parts are integrated during the mounting process.
13. After completion and pre-acceptance of the ceiling, the sequence of joints should be re-aligned. Soiled ceiling panels should be cleaned to give a perfect result for assembly.

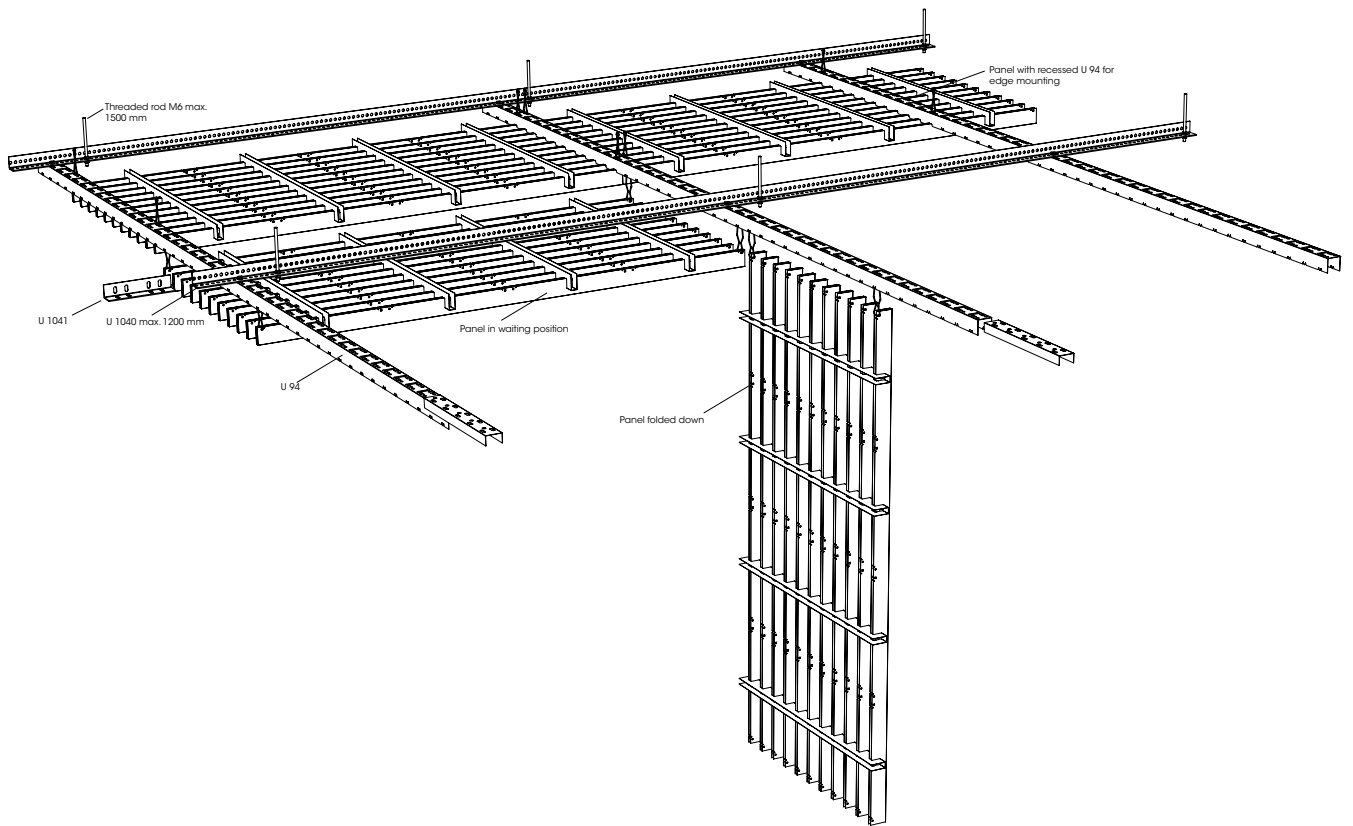
OPEN-CELL CEILINGS INSTALLATION MANUAL

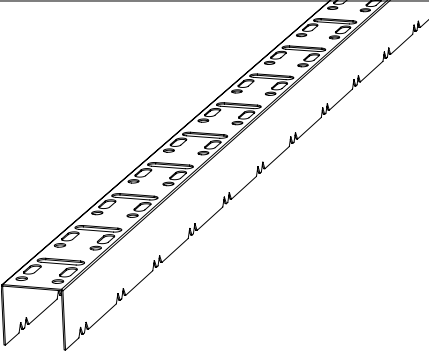
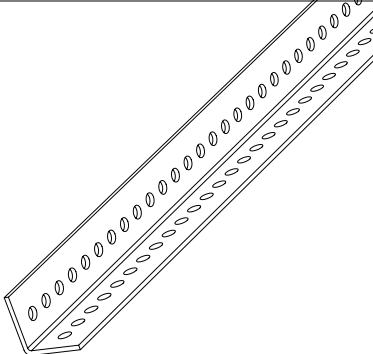
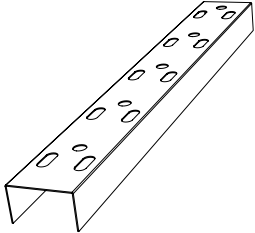
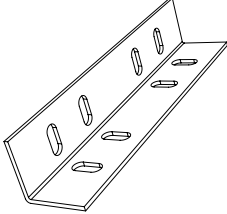

 <p>U 94</p>	 <p>U 1040</p>	 <p>V 94</p>
 <p>U 1041</p>	 <p>C 94</p>	 <p>Dismounting tool</p>

OPEN-CELL CEILINGS INSTALLATION MANUAL

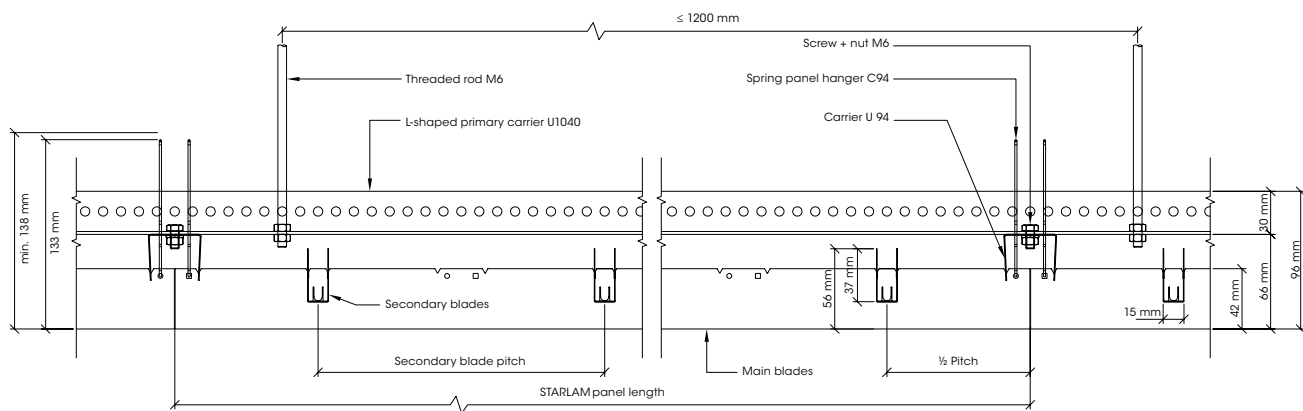

INSTALLATION OF THE COMPONENTS U 1040 UND U 94

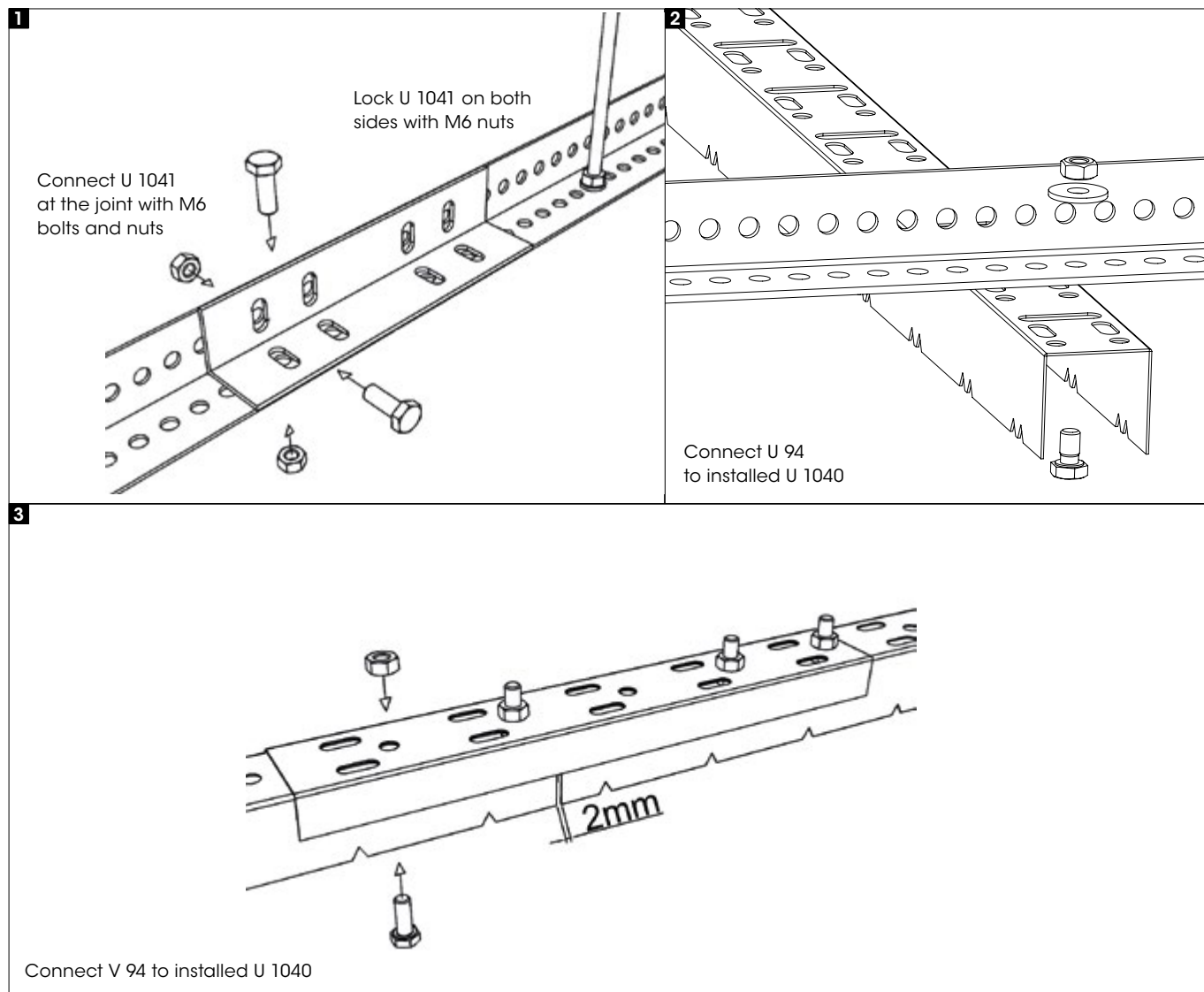

OPEN-CELL CEILINGS INSTALLATION MANUAL

INSTALLATION OF THE PANELS

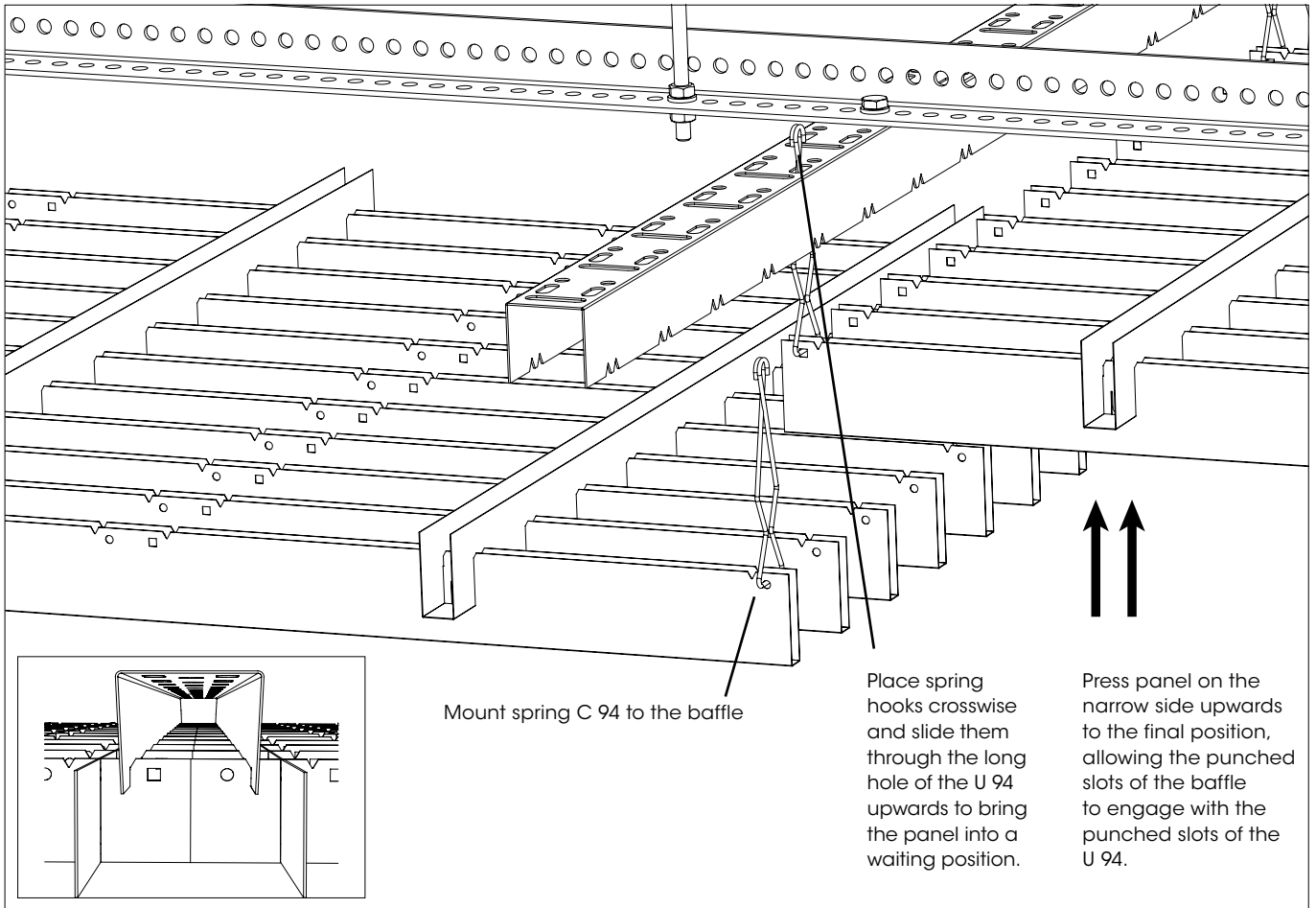

DISMOUNTING THE PANELS

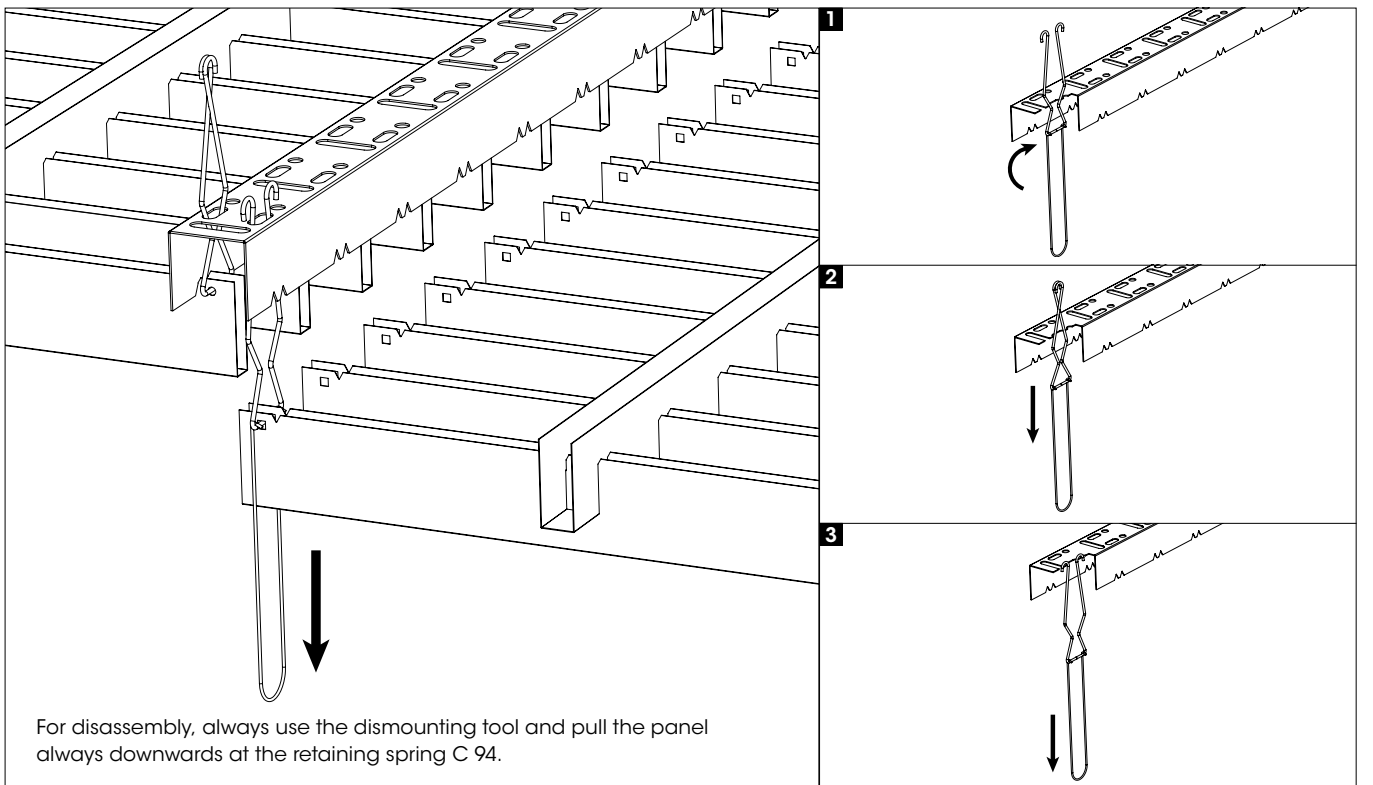

OPEN-CELL CEILINGS INSTALLATION MANUAL

ABBREVIATIONS

AP: Distance of primary profiles U 1040
AS: Distance of secondary profiles U 1005 A
AH: Distance of the suspension hangers in axial direction of the primary profile

DISTANCE OF THE SUSPENSIONS ETC.

Distance of the primary profiles AP according to EN 13964:

- Class 1: <1 000 mm
- Class 2: <1 200 mm

Distance of the secondary profiles AS according to EN 13964:

Depending on the panel length

Distance of the suspension points AH:

The distance of the suspension points AH is determined by the corresponding panel length. The L-shaped primary carrier serves mainly for cross bracing.

The maximum force applied to the suspension point may be 200 N. The corresponding suspension parts and dowels must be taken into account.

If it is not possible to specify in advance where the secondary profiles will run, select the following distances of the suspension points AH:

- Class 1: <1 000 mm
- Class 2: <1 200 mm

Load-carrying capacity of the suspension points [Tensile loads]:

- Maximum load per vernier suspension: 200 N
- Maximum load per threaded rod M6: 500 N
- Other loads must be verified statically.

Stress class according to EN 13964:

Stress class A according to Table 7

TO BE OBSERVED

- Use only officially approved dowels.
- The fastening base must be suitable in terms of statics. It must be able to reliably absorb the forces introduced into the construction.

ASSEMBLY OF THE SUSPENSION

Assembly of the wall bracket:

The regular distance for mounting the perimeter trim is max. 500 mm. This regular distance is less, depending on additional loads, the type of wall and special requirements.

1. Level and outline the given ceiling height.

2. Outline the upper edge of the perimeter trim.
3. Mark the drill hole.
4. Drill a hole for the dowel.
5. Secure the perimeter trim with a dowel.
6. Cleanly mitre cut the edges of the perimeter trim profiles.

Installation of the primary profile [U 1040]:

7. Outline the axis grid for the primary and secondary profiles.
8. Define the suspension points.
 - 8.1. The suspension hangers of the primary profile should be mounted as close as possible to the crossing point of the primary and secondary profiles. The maximum distance between the suspension hanger and the secondary profile is 100 mm [also see "Distance of the suspension points AH"].
 - 8.2. Module adapters [cross connectors] may not be mounted at the joint of the primary profiles.
 - 8.3. Keep a distance of at least 400 mm to the joint of the primary profiles.
 - 8.4. The maximum distance of a suspension point from the wall is 500 mm.
9. Drill a hole for the dowel.
10. Mount vernier scale upper part U 1300 or threaded rod M6 with dowels according to the manufacturer's instructions.
11. Cut L-shaped primary carrier U 1040 to the required length.
12. Fasten the vernier scale lower part U 1370 to the suspension points with a self-securing screw connection M6.
13. Place the L-shaped primary carrier U 1040 horizontally, vertically and aligned for the given ceiling height.
14. Secure vernier scale lower part U 1370 to vernier scale upper parts with two vernier scale safety pins U 1372. When using the threaded rod suspension, the threaded rod is guided through the horizontal shank of the L-shaped primary carrier and rigidly fastened with the self-securing screw connection M6.
15. The L-shaped primary carrier connector U 1041 is connected to the joint of the L-shaped primary carrier using a self-securing screw connection M6. Arrange the longitudinal connections of the profiles offset to one another.
16. When adjusting the height, observe the permissible height tolerances according to EN 13964, readjusting it, if necessary.
17. The primary profiles must be connected to the wall at least on one side with the wall bracket U 1042 to exclude any shift in axial direction.
18. Installation of the secondary profile U 94 without the primary profile is possible, but not recommended.

Installation of the secondary profile [U 94]:

19. Outline the predefined axis grid for the secondary profiles at the L-shaped primary carriers.
20. Cut U 94 carrier to the required length.
21. Align U 94 and connect it to the U 1040 primary grid using the M6 screw kit.
22. Centre the longitudinal connector V 94 above the joint of the U 94 profile and secure it with the M6 screw kit. Required longitudinal connections should be arranged in an offset manner.

INSTALLATION OF THE CEILING PANELS

1. Wear clean cotton gloves.
2. Mount four C94 retaining springs to the panel.
3. Hang retaining springs with panel into U94 - waiting position.
4. Engage panel with the V punched slots in the U94 - press upwards.
5. In case of a shadow gap, cut perimeter panels to size using a band saw.
6. U 94 may be offset to the inside by no more than 200 mm in case of perimeter installation.
7. Repeat steps 3 and 4 for installing the panels.
8. Optionally, install a perimeter trim.

DISASSEMBLY OF THE CEILING PANELS

1. Wear clean cotton gloves.
2. Use the delivered disassembly spring to pull the panel downwards into the waiting position at the suspension points (C 94).
3. Compress the retaining clips and unhook the panel from the mounting rail (U94) always only via the long side (long side vertically downwards) and fold it.

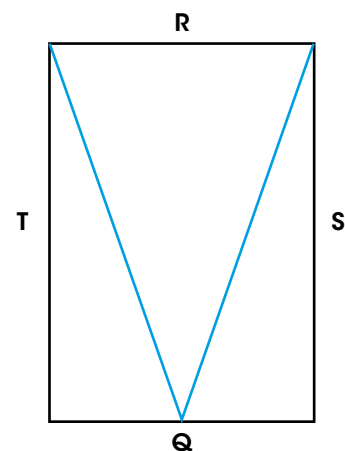

4. Deposit panel on a flat surface and store it protected from damage.

CEILING
LIGHTING
AMBIENCE

durlum GmbH | An der Wiese 5 | D-79650 Schopfheim

T +49 (0) 76 22 | 39 05-0
F +49 (0) 76 22 | 39 05-42
E info@durlum.com
I durlum.com